

The DW9255 is a Surface Acoustic Wave (SAW) bandpass filter for use with the GP2000 Global Positioning System (GPS) receiver chip-set, available from Mitel Semiconductor. It is pre-tuned to the exact 2nd IF filter requirements of the GP2010 & GP2015 RF front-end devices, with a centre-frequency of 35.42MHz. The response is tuned for a flat passband, steep stopband and uniform passband group-delay with 3 external inductors. The device is realised on a Lithium Tantalate substrate and housed in a small leadless ceramic Surface Mount package.

The DW9255 gives significant improvement in correlated GPS Signal-to-Noise Ratio (SNR) performance compared to conventional LC bandpass filter schemes. This aids satellite signal acquisition and tracking capability from the GP2000 GPS chip-set. This device effectively filters out-of-band (unwanted) noise in the GPS signal. The Automatic Gain Control (AGC) within the GP2010 and GP2015 RF Front-end devices will then operate only on in-band noise for optimum gain and superior correlated GPS signal strength.

**FEATURES**

- Centre Frequency of 35.42MHz
- Insertion Loss of 17dB ±1dB (typical)
- 1dB Bandwidth 1.9MHz (typical)
- Passband Ripple 0.8dB (typical)
- Low Profile Ceramic Surface Mount Package
- Operating Temperature Range -40° to +85°C

**APPLICATION**

- Commercial Global Positioning

**RELATED PRODUCTS AND PUBLICATIONS**

Part	Description	Data Reference
GP2010	GPS receiver RF Front-end	DS4056
GP2015	Miniature GPS receiver RF Front-end	DS4374

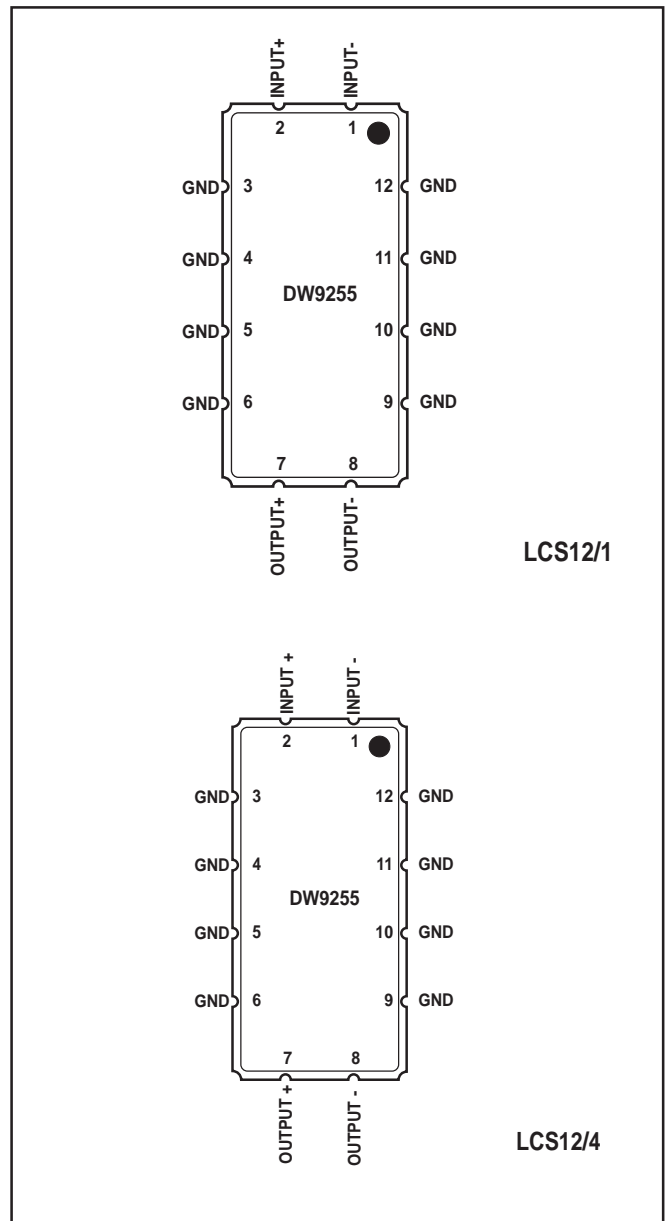

Fig.1 Pinout

**DW9255**

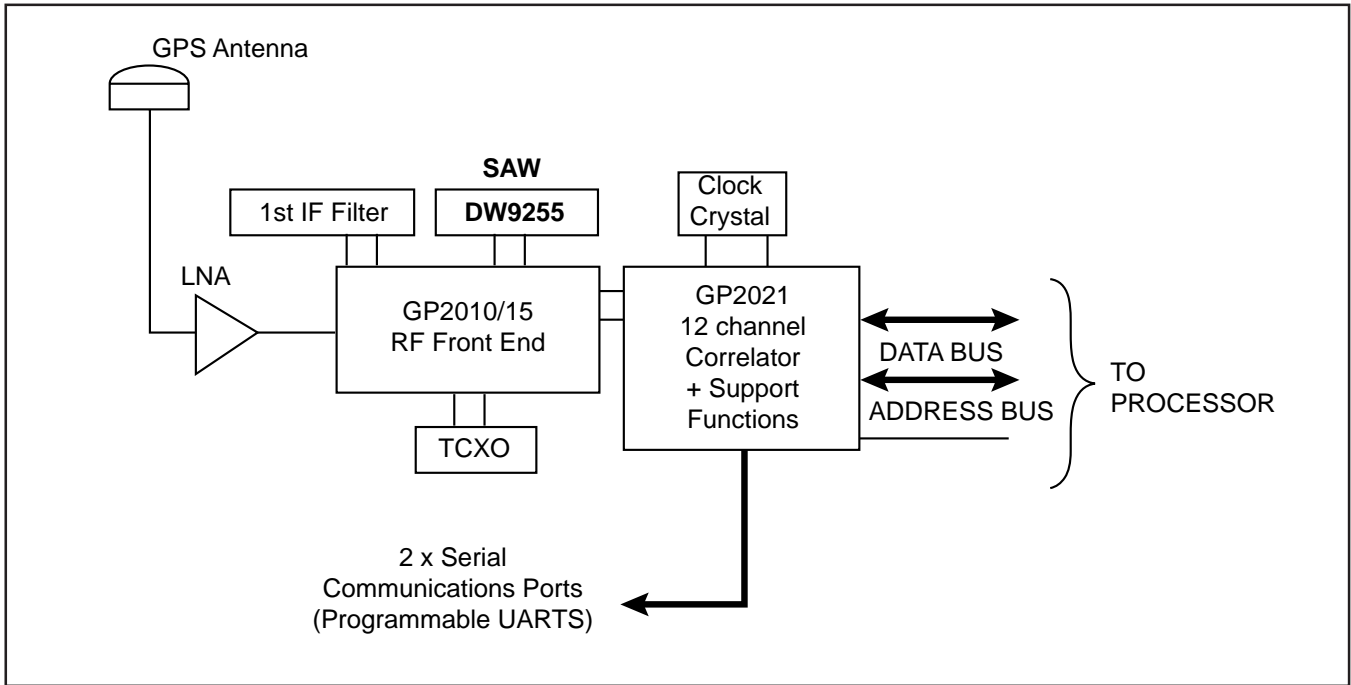

Fig.2 DW9255 used with GPS chipset

**ELECTRICAL CHARACTERISTICS** (Typ. @ 25°C)

Parameter	Min	Typ	Max	Units
Centre Frequency	-	35.42	-	MHz
1dB Bandwidth	1.6	1.9	-	MHz
Insertion Loss	16	17	18	dB
Amplitude Ripple (34.62 to 36.22MHz)	-	0.8	1.6	dB (pk to pk)
Relative Attenuation (relative to insertion loss)				
<28MHz	35	40	-	dB
<31MHz	30	35	-	dB
<33.5MHz	21	25	-	dB
>37.5MHz	21	25	-	dB
>40MHz	25	30	-	dB
>50MHz	30	40	-	dB
>63MHz	28	35	-	dB
>73 - 110MHz	40	45	-	dB
Group Delay Ripple (34.62 to 36.22MHz)	-	190	300	ns
Maximum Group Delay (34.62 to 36.22MHz)	-	1.6	1.7	µs
Operating Temperature Range	-40	-	+85	°C

**DW9255 used as 2nd IF filter for GP2010/15**

Centre Frequency	35.42MHz
Pass Band	±1.0MHz (within ±1.0dB)
Insertion loss	14-18dB
3rd IF Image frequency at 2nd IF	26.8MHz
Source Impedance	500Ω typical
Load Impedance	1000Ω typical

than 20dB) beyond this bandwidth, and so should have a brick-wall type response at these extremes. The DW9255 SAW filter provides a 1dB Bandwidth of typically 1.9MHz centred on 35.42MHz, with a typical pass band ripple of 0.8dB, when the SAW input and output capacitance is resonantly matched with inductors of optimum value. The out-of-band signal rejection is better than 21dB at ±2.0MHz, and better than 35dB at ±7.5MHz.

The second external IF filter is connected between the output of Stage 2 and input of Stage 3. It is required to define the bandwidth of the RF section of the GPS receiver, hence it is critical to the receiver performance. The filter should be flat across the 2MHz bandwidth of the GPS Coarse-Acquisition (C/A) code signal. It should also have high rejection (greater

The frequency response of the DW9255 SAW filter with matching components is shown in Fig. 3. The matching components used with the GP2010/15 device are shown in Fig. 4.

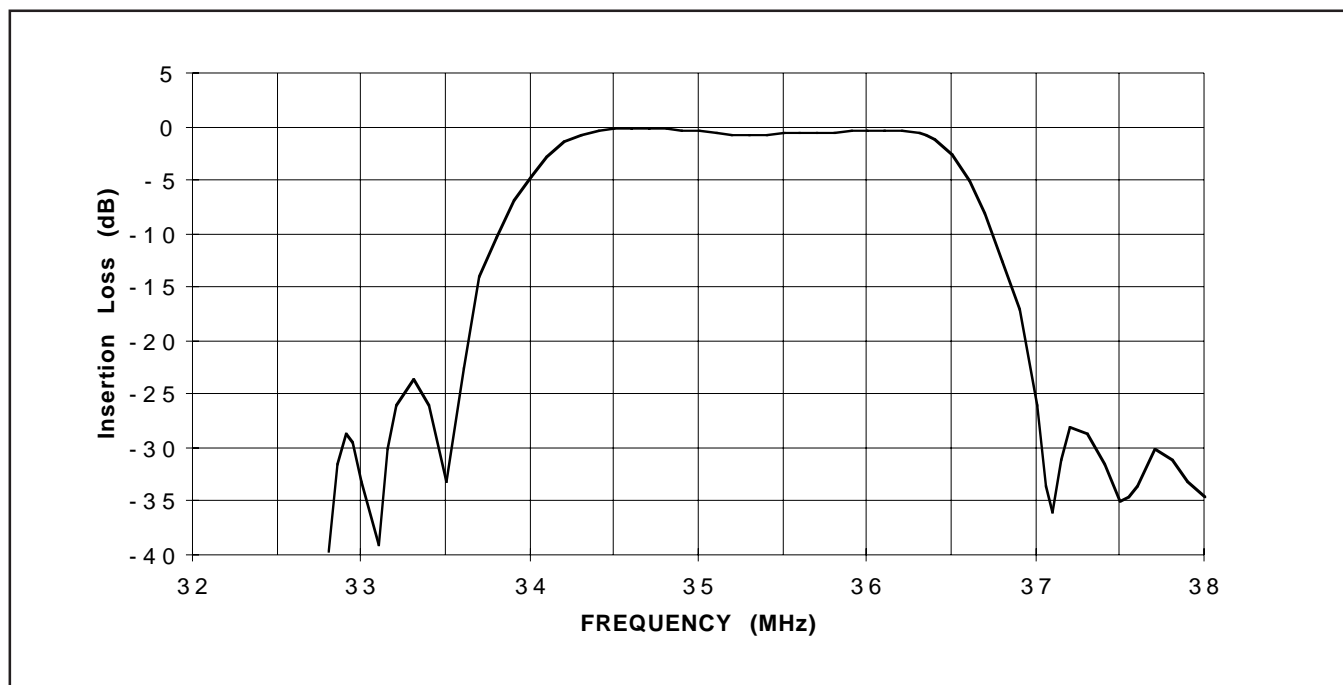

*Fig.3 Typical frequency response of DW9255 SAW filter used as 2nd IF filter*

DW9255

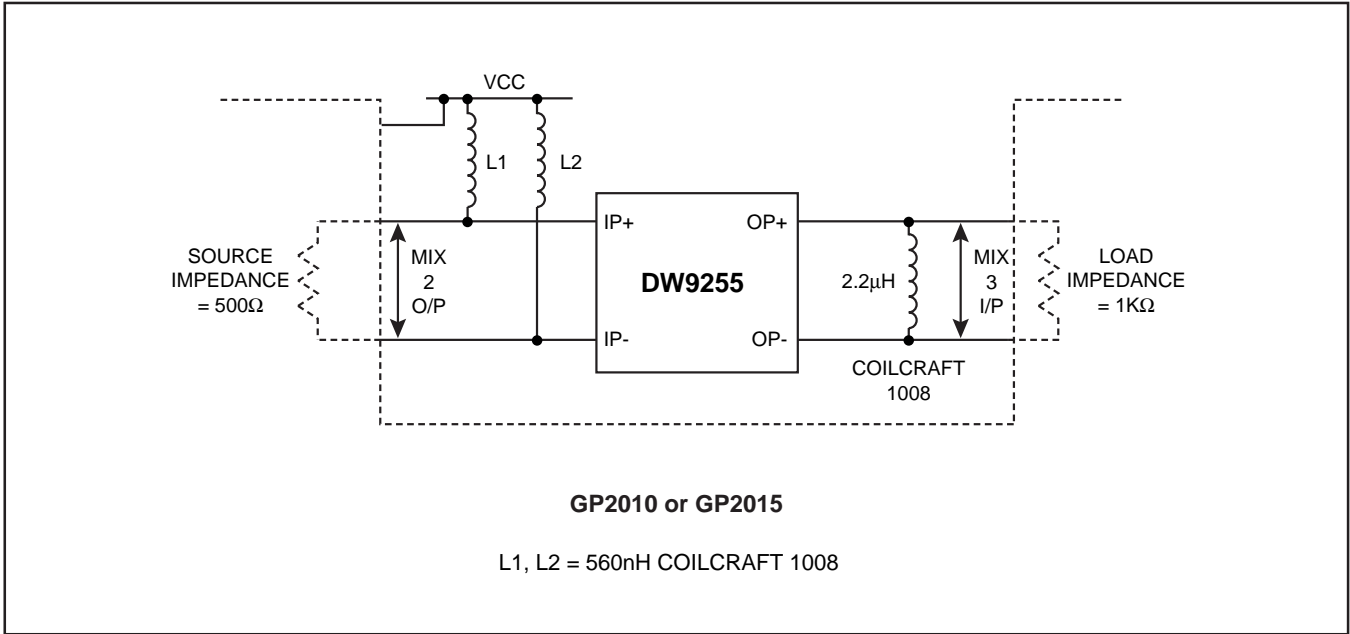

Fig.4 Typical matching components when used with GP2010 or GP2015 GPS Front-end IC

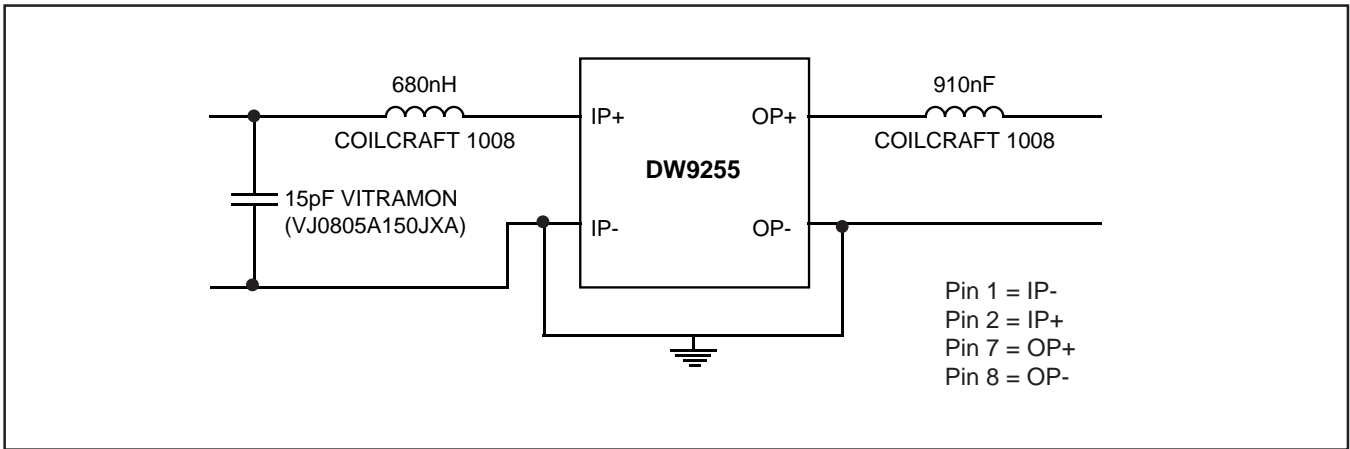

Fig.5 50Ω Matching network



# DW9255

## PACKAGE DETAILS

Dimensions are shown thus: mm (in). For further package information, please contact your local Customer Service Centre.

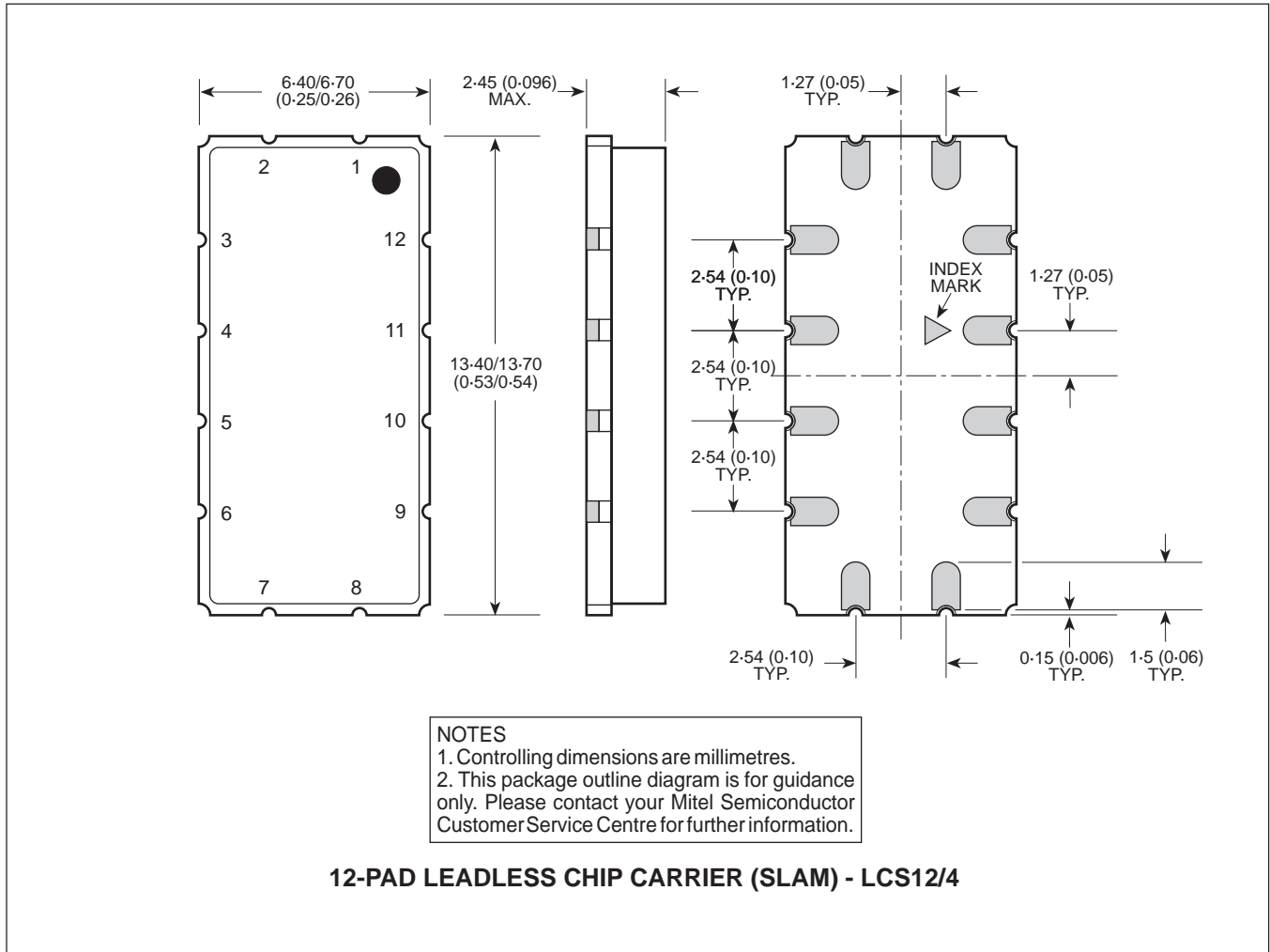

HEADQUARTERS OPERATIONS  
**MITEL SEMICONDUCTOR**  
Cheney Manor, Swindon,  
Wiltshire SN2 2QW, United Kingdom.  
Tel: (01793) 518000  
Fax: (01793) 518411

**MITEL SEMICONDUCTOR**  
1500 Green Hills Road,  
Scotts Valley, California 95066-4922  
United States of America.  
Tel (408) 438 2900  
Fax: (408) 438 5576/6231

Internet: <http://www.gpsemi.com>  
CUSTOMER SERVICE CENTRES

- **FRANCE & BENELUX** Les Ulis Cedex Tel: (1) 69 18 90 00 Fax : (1) 64 46 06 07
- **GERMANY** Munich Tel: (089) 419508-20 Fax : (089) 419508-55
- **ITALY** Milan Tel: (02) 6607151 Fax: (02) 66040993
- **JAPAN** Tokyo Tel: (03) 5276-5501 Fax: (03) 5276-5510
- **KOREA** Seoul Tel: (2) 5668141 Fax: (2) 5697933
- **NORTH AMERICA** Scotts Valley, USA Tel: (408) 438 2900 Fax: (408) 438 5576/6231
- **SOUTH EAST ASIA** Singapore Tel:(65) 3827708 Fax: (65) 3828872
- **SWEDEN** Stockholm Tel: 46 8 702 97 70 Fax: 46 8 640 47 36
- **TAIWAN, ROC** Taipei Tel: 886 2 25461260 Fax: 886 2 27190260
- **UK, EIRE, DENMARK, FINLAND & NORWAY**  
Swindon Tel: (01793) 726666 Fax : (01793) 518582

These are supported by Agents and Distributors in major countries world-wide.

© Mitel Corporation 1998 Publication No. DS3861 Issue No. 3.1 November 1997

TECHNICAL DOCUMENTATION – NOT FOR RESALE. PRINTED IN UNITED KINGDOM

This publication is issued to provide information only which (unless agreed by the Company in writing) may not be used, applied or reproduced for any purpose nor form part of any order or contract nor to be regarded as a representation relating to the products or services concerned. No warranty or guarantee express or implied is made regarding the capability, performance or suitability of any product or service. The Company reserves the right to alter without prior notice the specification, design or price of any product or service. Information concerning possible methods of use is provided as a guide only and does not constitute any guarantee that such methods of use will be satisfactory in a specific piece of equipment. It is the user's responsibility to fully determine the performance and suitability of any equipment using such information and to ensure that any publication or data used is up to date and has not been superseded. These products are not suitable for use in any medical products whose failure to perform may result in significant injury or death to the user. All products and materials are sold and services provided subject to the Company's conditions of sale, which are available on request.

All brand names and product names used in this publication are trademarks, registered trademarks or trade names of their respective owners.